

Dual Axis Solar Tracking System Using Pic Microcontroller

Dr. Eyad Ibrahim Dr. wasif al saluos

Faculty of Engineering Technology, Electrical Engineering Department, Zarqa University
Supported by Zarqa University

Abstract: Increasing the efficiency of solar photo module is solar tracking system. This study presents the energy conversion of photo module with solar tracking system. This research is to development of an Automatic Solar Tracking System by using PIC microcontrollers and dc motor. To have solar systems energy more viable, the efficiency of solar array systems have to be maximized by follow the sun radiations using sun tracking systems. Our studies focuses on controls of the solar array movement towards the direction of the sun radiation. Automatic Sun Tracking System is a hybrid hardware/software prototype, which is automatically provides best alignment of solar panel with the sun, to get maximum electrical output power. Programmable Interface Controller (PIC) is widely accepted industrial control device. Simplicity, stand-alone, high speed, and low cost. In our study "PIC 18F452" is used which has a good range of features and the programmable language is relatively simple.

Keywords: Photo module, Microcontroller, Solar energy, Sun tracking system.

I. Introduction

Light intensity is the big problem with solar power generation. To produce the maximum energy, a solar panel must be vertically and face to face to the light source. Because the sun moves both throughout the day as well as throughout the year, a solar panel must be able to follow the sun's movement to produce the maximum possible power. The solution is to use a tracking system that maintains the panel's orthogonal position with the light source. There are many tracking system designs available including passive and active systems with one or two axes of freedom.

Solar trackers are used to improve electric power radically of photovoltaic panel by using different sensor. The sensors retrieve the solar radiation. This study presents a simple method, low cost microcontroller based solar tracker of two ways of rotating freedom in order to achieve the right positioning of photovoltaic solar cell to get the much sunlight during the day light session and as a result produce more electricity. This tracking system is developed with two direct current motor operated by a PIC18452 microcontroller which processes the sensors (LDR) data by its internal ADC-analog to digital converter and send the correct data to motor controller IC-L298N to run the motor in two directions.

The goal of our project to design an active, dual axis solar tracker that will have a minimum allowable error. We designed and tested several mechanical and electrical options and chose best one with the most desirable characteristics. Finally, we built our final tracking system module, tested to ensure that we met our original goal.

II. Objectives

The main objective is to design and develop a prototype of PIC controlled solar system that actively tracks the sun so that maximum power is received by the array at all time of the day. Tracking systems try to collect the largest amount of solar radiation and convert it into usable form of electrical energy (DC voltage) and store this energy into batteries for different types of applications. The sun tracking systems can collect more energy than fixed panel system collects,



Fig(1) System Diagram

Solar Energy and PV characteristics

Photovoltaic (PV), the technology which converts sunlight into electricity, is one of the fastest growing sectors of the renewable energy industry. It is already well established in many countries and looks set to become one of the technologies of the 21st century.

Solar Energy In Jordan

Jordan is blessed with an abundance of solar energy which is evident from the annual daily average solar irradiance (average insolation intensity on a horizontal surface) ranges between 4-7 kWh/m², which is one of the highest values in the world. This corresponds to a total annual of 1400-2300 kWh/m². The average sunshine duration is more than 300 days per year. [16]

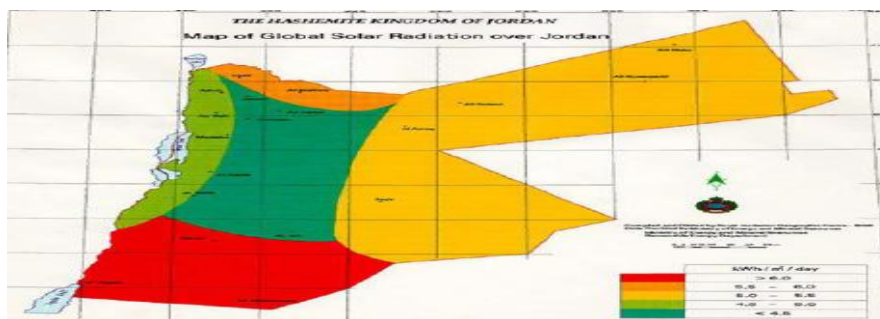

Fig (2): Map of solar radiation over Jordan

Solar cell

The most common material used in solar cells is single crystal silicon. Solar cells made from single crystal silicon are currently limited to about 25% efficiency because they are most sensitive to infrared light, and radiation in this region of the electromagnetic spectrum is relatively low in energy. Fig (3) shows photo of single crystal solar cells.



Fig (3): Single crystal solar cell

The sunlight comes in and strikes the panel at an angle. The angle of the sunlight to the normal is the angle of incidence (θ). Assuming the sunlight is staying at a constant intensity (λ) the available sunlight to the solar cell for power generation (W) can be calculated as:

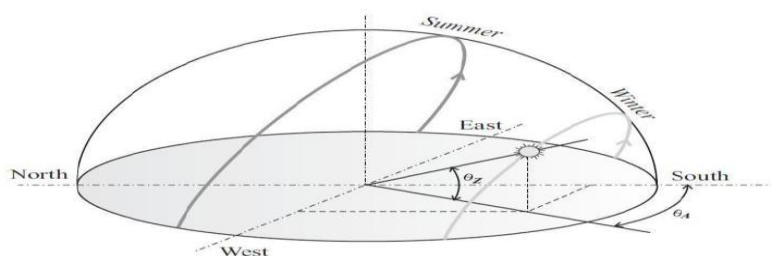

Fig (4): Solar altitudes and azimuths typical behavior of sun path.

Types of Tracking System

There are two type of tracking system; one is a single axis tracking system and another is dual-axis tracking system. [9]

Single axis solar tracker: Single axis solar tracker can either have a horizontal or a vertical axis. The horizontal axis type used in tropical regions where the sun gets very high at noon, but the days are short. The vertical type is used in high latitudes where the sun does not get very high, but summer days can be very long. The single axis solar tracker is the simplest solution and the most common one used, Fig (5) show this system.

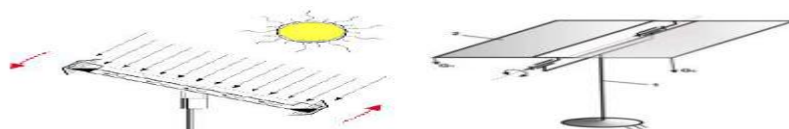

Fig (5) : Single axis tracker

Dual axis solar tracker: Dual axis solar tracker have both a horizontal and a vertical axis and so can track the sun's apparent motion exactly anywhere in the world. This type of system is used to control astronomical telescopes, and so there is plenty of software available to automatically predict and track the motion of sun across the sky. By tracking the sun, the efficiency of solar panels can be increased by 30-40%. The dual axis tracking system is also used for concentrating a solar reflector toward the concentrator on heliostat systems; fig (6) shows this system.

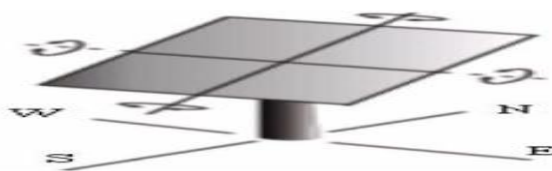

Fig (6) : Dual axis tracker

In this study we design the dual axis solar tracker by controlling of both axes vertical and horizontal.

System Over view operation

A deep look to the hardware must take place in this chapter. As shown in figure below, the overall schematic diagram is introduced; the connection between the microcontroller and every component will be discussed in details.

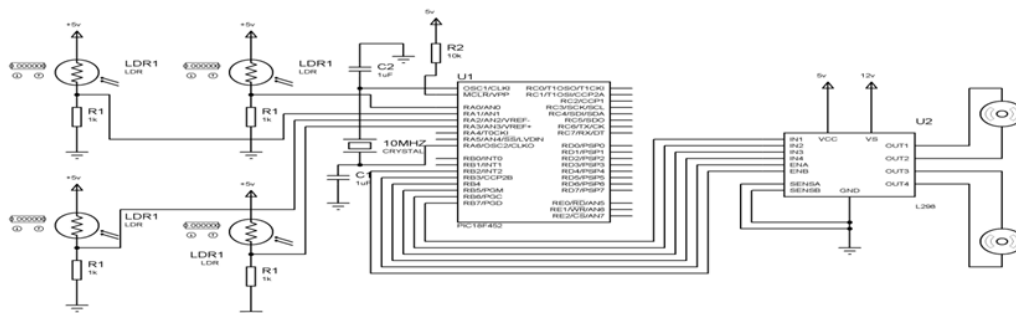

Fig (7): Overall schematic diagram

In this study, four Light Dependent Resistors (LDR) are used for measuring the intensity of the sun's rays that's important to permit the solar panel tracking the sun. a simple conditioning circuit (voltage divider) is used to convert the changing value of LDR to analog voltage.

A Microcontroller is used to read the analog value of LDRs and convert it to digital via Analog to Digital Converter (ADC) that is embedded inside it. The Microcontroller also is connected with Motor Driver (H-bridge), to control the direction of the two motor according of the LDRs readings. At each axis of solar panel, two LDRs are fixed. The Microcontroller will read the analog output from the two LDRs and compare it together to decide if the Motor will run CW, CCW or OFF.

Light Dependent Resistor (LDR): A photo resistor or light dependent resistor is a component that is sensitive to light. When light falls upon it then the resistance changes. [7]



Fig (8): Light Dependent Resistor

Dc motors: The d.c motor show in Fig (9) is used when its operate at 12V dc , as we mentioned earlier the PV panel produced power at 12V DC which more easier to used this voltage without any converting of it . [5]



Fig (9) : Dc motor

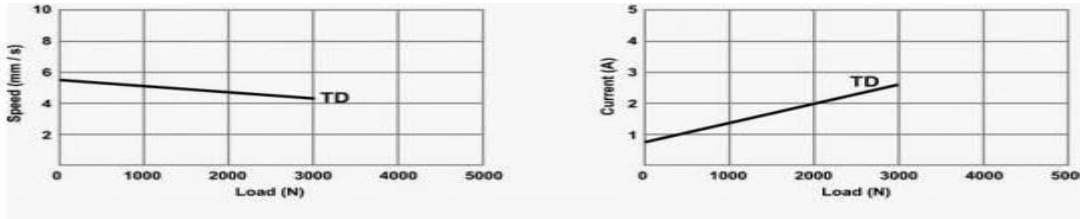

Fig (10) : Characteristics of dc motor

PIC Microcontroller: PIC microcontrollers is a kind of programmable microcontroller which produced by microchip, it can be programmed by many programming language.[3]

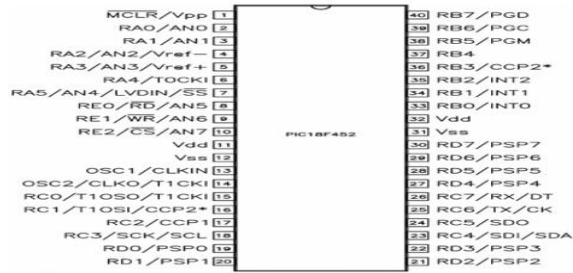

Fig (11): PIC Microcontroller Chip

H-Bridge (L298N); The Motor Shield is based on the L298, which is a dual full-bridge driver. It lets you drive two DC motors , controlling the speed and direction of each one independently. The L298 is an integrated monolithic circuit has a high voltage, high current dual full-bridge driver designed to accept standard TTL logic levels. [2]

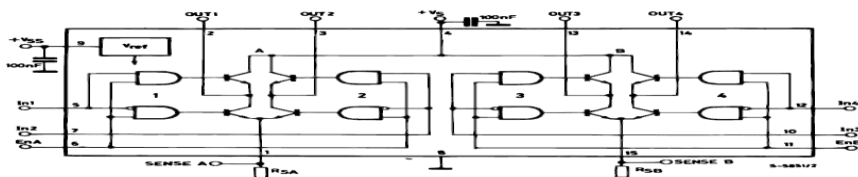

Fig (12): Block diagram of h-bridge (L298N)

Software Implementation

The flow chart of program shown in Fig (13) below:

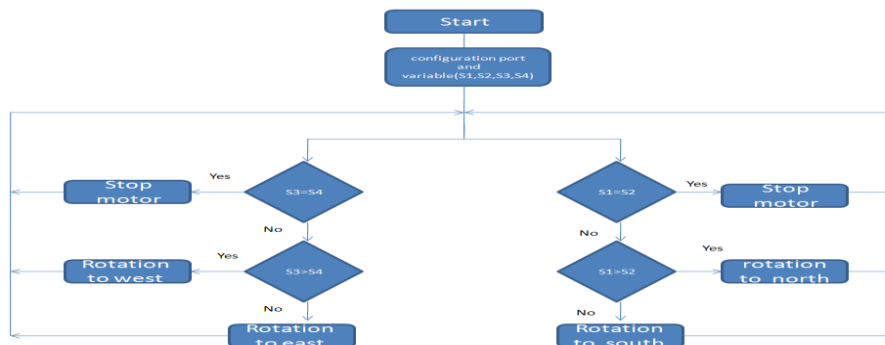

Fig (13) : Flow chart of program

PIC Programming steps: We are selecting the com number as shown below in Fig (14). [6]

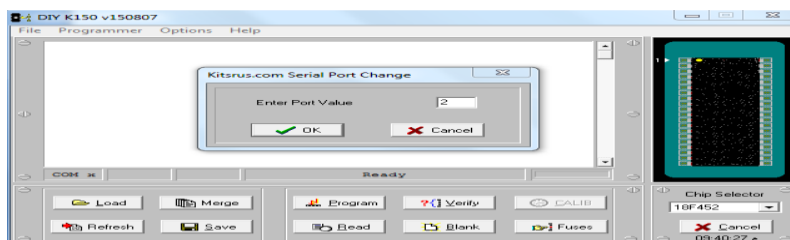

Fig (14) : Select the com number

Select the type of PIC microcontroller::DIY K150 When first start this is the screen in the Fig (15) for selecting .Type of PIC which is (PIC 18F452), and have been selected.

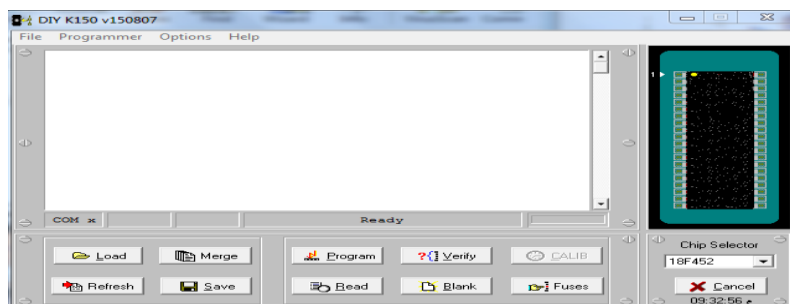

Fig (15): Selecting the pic microcontroller

Load Hex file:

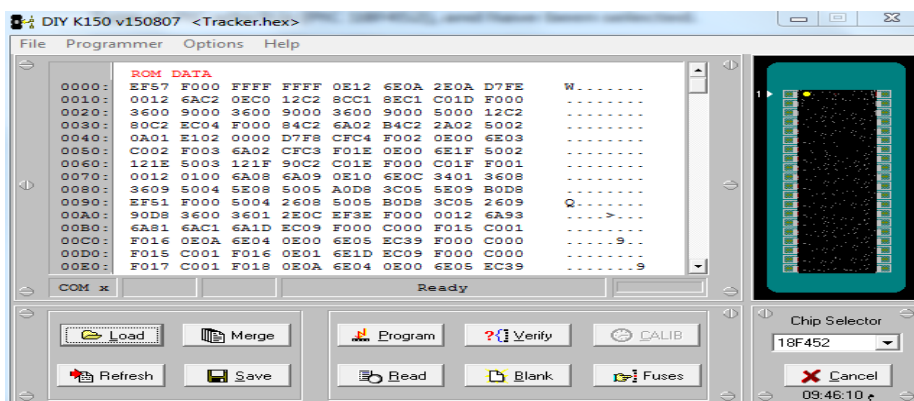

Fig (16) : Loading Hex file

Transfer the program to the PIC chip: By using the option of DIY K150, click on program option to transfer it.

Major system components: Solar PV system includes different components that should be selected according to our system type, site location and applications. The major components for solar PV system are solar charge controller, inverter and battery bank, auxiliary. [17]

Generated power for fixed, single and dual axis tracking table.

Time	Fixed	Single	Dual
7 am	0.151	7.15	7.3
8 am	0.968	9.27	9.1
9 am	12.96	18	19.1
10	15.7	20	20.43
11	21.36	23	23.5
12	25.38	32.8	31.3
1 pm	27.45	40	42
2 pm	18.15	29.6	30.97
3 pm	13.34	21.56	21.85
4 pm	7.20	13.86	12.5
5 pm	0.54	0.85	0.95

III. Conclusions

- 1- The Renewable energy such as solar energy is important in our life because the non-renewable such as fossil fuel contribute significantly to many of the environmental problems we face today. In this study the solar energy can be used to generate electricity. Photovoltaic cell systems convert sunlight directly into electricity. PV cell consists of semi-conducting material that absorbs the sunlight.
- 2- The Efficiency for dual axis tracking solar cell is more.
- 3- By tracking systems way the customer can get the maximum power from the solar cell, that is important in solar power system because it reduce the number of solar array to obtain the desired output power .
- 4- A single axis tracker increases annual output by approximately 30%, and a dual axis tracker an additional 6%.

References

- [1]. <http://cogeneration.net/tag/renewable-energy-2/>
- [2]. <http://fish.washington.edu/people/gordie/Washrenewres.html>
- [3]. <http://www.123eng.com/projects/SOLAR%20VS%20NUCLEAR%20VS%20WIND%20ENERGY.pdf>. [4]-http://schools-wikipedia.org/wp/p/Photovoltaic_array.htm
- [4]. B.lane , " solar tracker "
- [5]. http://umpir.ump.edu.my/308/1/EG05027-MARLIYANI_OMAR.PDF
- [6]. M.saleem , " Efficient implementation of off-grid solar power system"
- [7]. sandia national laboratories , " battery and charge control in standalone PV system
- [8]. <http://www.solardirect.com/pv/systems/systems.htm>
- [9]. <http://www.scribd.com/doc/45730949/INVERTERS>
- [10]. <http://in.answers.yahoo.com/question/index?qid=20080930074138AASNI3d>
- [11]. <http://hyperphysics.phy-astr.gsu.edu/hbase/electric/powerac.html>
- [12]. <http://www.focusvoltaico.com/en/solar-energy-production-estimation.html>
- [13]. http://www.eeaa.gov.eg/english/reports/seam/e1_9.pdf
- [14]. http://www.societyofrobots.com/actuators_servos.shtml
- [15]. Meteorological Department
- [16]. http://www.leonics.com/support/article2_12j/articles2_12j_en.php
- [17]. Batteries and charge control in stand-alone photovoltaic systems fundamentals and application by (james p. Dunlop).